

CARTER ACEITE - Oil pan - Coppa olio

MOTOR - Engine - Motore
F20 & F25

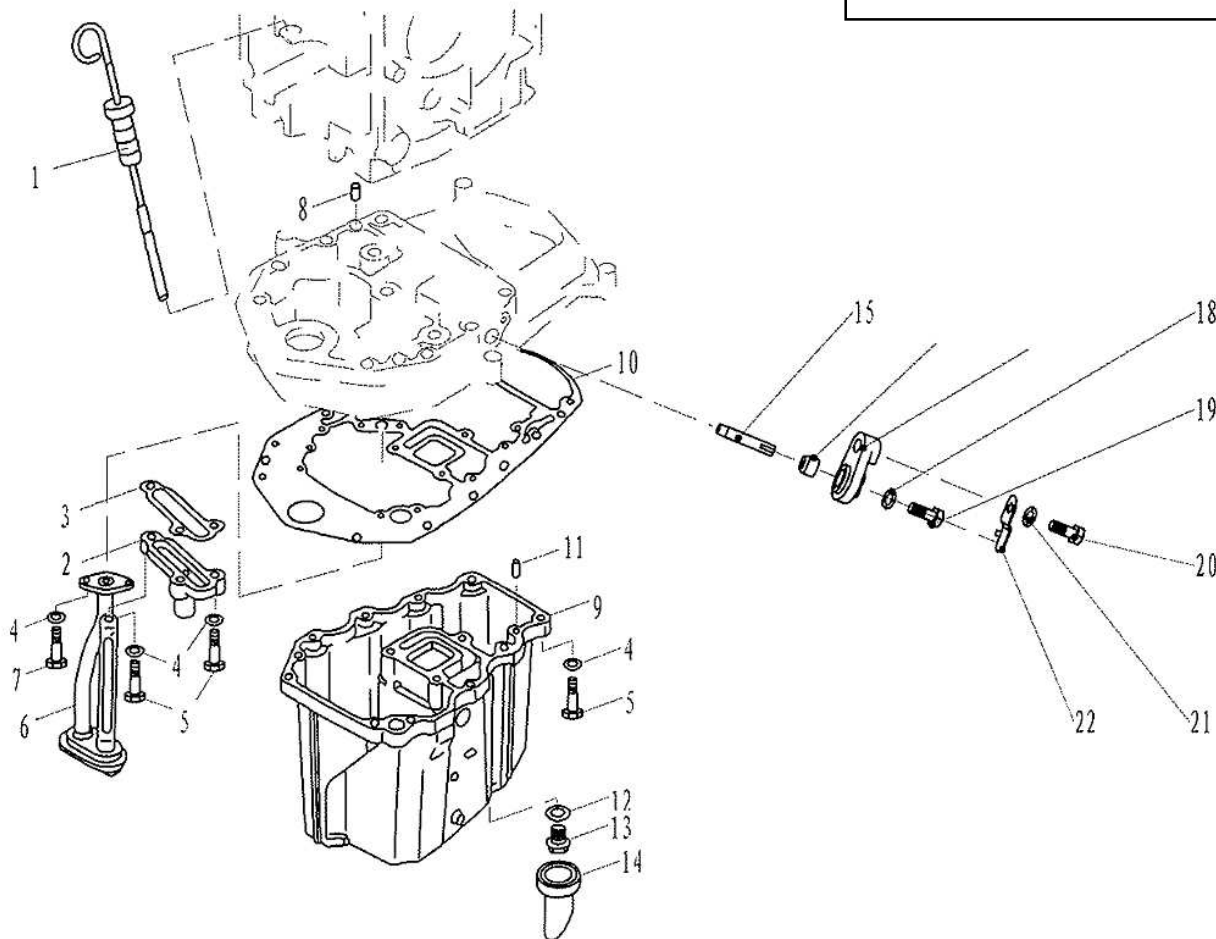

Nº	REF. PARSUN Ref. Parsun Ref. Parsun	DESCRIPCIÓN Description Descrizione	CANTIDAD Quantity Quantità
1	PAF25-00000100	PLUG, OIL LEVEL	1
2	PAF25-02010100	RELIEF VALVE AUY	1
3	PAF25-02010006	GASKET, RELEIF VALVE	1
4	PAGB/T97.1-2000	WASHER, PLAIN	15
5	PAGB/T5783-2000	HEXAGON BOLT	13
6	PAF25-02010200	STRAINER, OIL	1
7	PAGB/T5783-2000	HEXAGON BOLT	2
8	PAF25-00000014	PIN, DOWEL	2
9	PAF25-02000006	OIL SUMP	1
10	PAF25-02010007	HEXAGON BOLT	1
11	PAF15-00000006	PIN, DOWEL	2
12	PAF15-04000003	GASKET	1
13	PAF15-04000002	BOLT, OIL DRAIN	1
14	PAF25-02000007	JACKET, OIL DRAIN	1
15	PAF25-02010005	ANODE	1
16	PAF15-07010009	SEAL, ANODE	1
17	PAF15-07010011	COVER, ANODE	1
18	PAGB/T97.1-1985	WASHER	1
19	PAGB/T5783-2000	BOLT	1
20	PAGB/T5783-2000	BOLT, HEXAGON	1
21	PAGB/T97.1-1985	WASHER	1
22	PAF15-07010012	PLATE, ANODE	1